

This range of stainless steel cylinders has been specially designed for use in difficult environments. Hygienic design, external seals of flouriated rubber and prelubrication with our food-industry-approved grease according to USDA-H1 make the cylinders particularly suitable for food industry use. All cylinders have magnetic pistons for proximity position sensing. Fixing dimensions to ISO 6432 simplify installation and make the cylinders physically interchangeable throughout the world.



- Mini - cylinders according to ISO 6432
- All stainless in 10 to 25 mm bores
- Magnetic piston as standard
- Double and single acting
- End stroke buffers for long service life
- Available with adjustable cushioning

Operating information

Working pressure: Max 10 bar
 Temperature range: -20°C to +80°C Ø10-25mm

Prelubricated, further lubrication is not normally necessary. If additional lubrication is introduced it must be continued.

For more information see www.parker.com/euro_pneumatic

Double acting buffer cushioning

Ø10mm - (M5)

Stroke mm	Order code
10	P1S-S010DS-0010
15	P1S-S010DS-0015
25	P1S-S010DS-0025
40	P1S-S010DS-0040
50	P1S-S010DS-0050
80	P1S-S010DS-0080
100	P1S-S010DS-0100
125	P1S-S010DS-0125

Ø12mm - (M5)

Stroke mm	Order code
10	P1S-S012DS-0010
15	P1S-S012DS-0015
25	P1S-S012DS-0025
40	P1S-S012DS-0040
50	P1S-S012DS-0050
80	P1S-S012DS-0080
100	P1S-S012DS-0100
125	P1S-S012DS-0125
160	P1S-S012DS-0160
200	P1S-S012DS-0200

Ø16mm - (M5)

Stroke mm	Order code
10	P1S-S016DS-0010
15	P1S-S016DS-0015
25	P1S-S016DS-0025
40	P1S-S016DS-0040
50	P1S-S016DS-0050
80	P1S-S016DS-0080
100	P1S-S016DS-0100
125	P1S-S016DS-0125
160	P1S-S016DS-0160
200	P1S-S016DS-0200

Ø20mm - (G1/8)

Stroke mm	Order code
10	P1S-S020DS-0010
15	P1S-S020DS-0015
25	P1S-S020DS-0025
40	P1S-S020DS-0040
50	P1S-S020DS-0050
80	P1S-S020DS-0080
100	P1S-S020DS-0100
125	P1S-S020DS-0125
160	P1S-S020DS-0160
200	P1S-S020DS-0200
250	P1S-S020DS-0250
320	P1S-S020DS-0320

Ø25mm - (G1/8)

Stroke mm	Order code
10	P1S-S025DS-0010
15	P1S-S025DS-0015
25	P1S-S025DS-0025
40	P1S-S025DS-0040
50	P1S-S025DS-0050
80	P1S-S025DS-0080
100	P1S-S025DS-0100
125	P1S-S025DS-0125
160	P1S-S025DS-0160
200	P1S-S025DS-0200
250	P1S-S025DS-0250
320	P1S-S025DS-0320

Double acting adjustable cushioning

Ø20mm - (G1/8)

Stroke mm	Order code
15	P1S-S020MS-0015
25	P1S-S020MS-0025
40	P1S-S020MS-0040
50	P1S-S020MS-0050
80	P1S-S020MS-0080
100	P1S-S020MS-0100
125	P1S-S020MS-0125
160	P1S-S020MS-0160
200	P1S-S020MS-0200
250	P1S-S020MS-0250
320	P1S-S020MS-0320

Ø25mm - (G1/8)

Stroke mm	Order code
15	P1S-S025MS-0015
25	P1S-S025MS-0025
40	P1S-S025MS-0040
50	P1S-S025MS-0050
80	P1S-S025MS-0080
100	P1S-S025MS-0100
125	P1S-S025MS-0125
160	P1S-S025MS-0160
200	P1S-S025MS-0200
250	P1S-S025MS-0250
320	P1S-S025MS-0320

Design Variants

Working temperatures

High temperature

Ø10 and Ø16mm -10°C to +120°C Non-magnetic piston

Ø20 and Ø25mm -10°C to +150°C Non-magnetic piston

Low temperature

Ø10, 12 and 16mm -40°C to +60°C Non-magnetic piston



Double acting options

Effective end-cushioning

A version of ISO 6432 Ø10-Ø25 incorporates fixed end-cushioning, while the cylinders Ø20-Ø125 have pneumatic end-cushioning with adjusting screws for exact setting, permitting heavier loads and higher speeds for short cycle times.

Double-acting adjustable cushioning	Ø20 - Ø25 (not for seal material type F and L)
Double-acting non-adjustable cushioning	Ø10 - Ø25



Double-acting, adjustable cushioning through rod	Ø20 - Ø25 (not for seal material type F and L)
Double-acting, non-adjustable cushioning through rod	Ø10 - Ø25
Double-acting, adjustable cushioning through rod, hollow	Ø20 - Ø25 (not for seal material type F and L)
Double-acting, non-adjustable cushioning through rod, hollow	Ø20 - Ø25 max stroke 125mm



Single acting options

Single-acting, Spring return for retracted stroke. Non-adjustable cushioning	Ø10 - Ø25
Single-acting, Spring extended for advanced stroke. Non-adjustable cushioning	Ø20 - Ø25



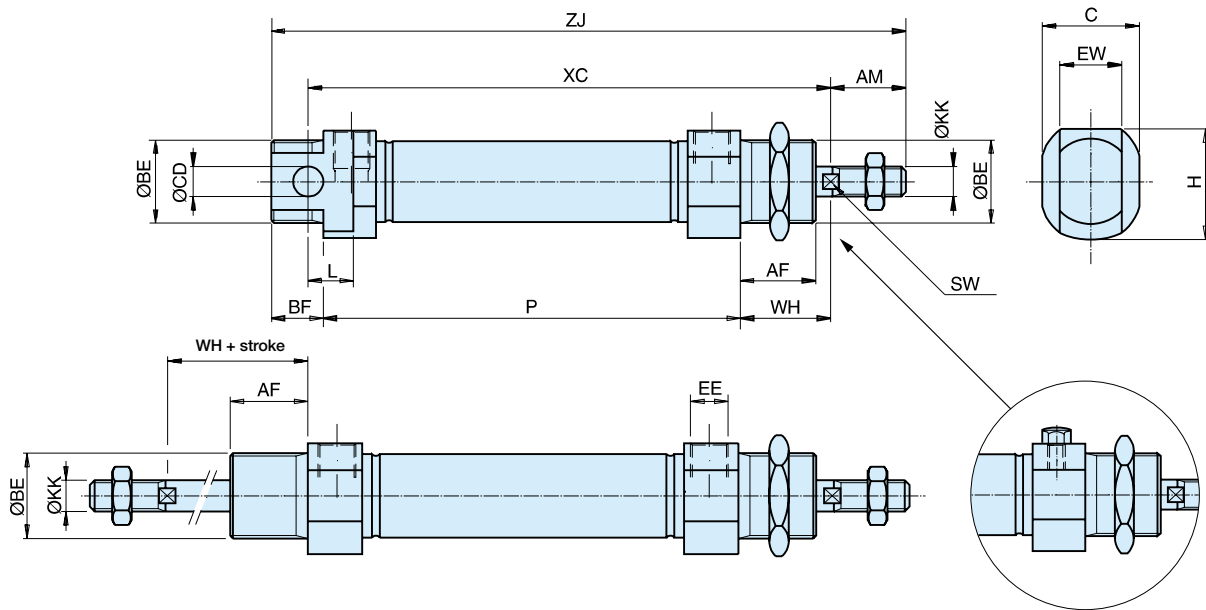

Dimensions

Cyl. bore mm	AM 0/-2 mm	BE	AF mm	BF mm	C mm	CDH9 mm	EE	EW mm	H mm	KK	L mm	SW mm	WH±1,2 mm
10	12	M12x1,25	12	10	14	4	M5	8	19	M4	6	-	16
12	16	M16x1,5	18	13	18	6	M5	12	19	M6	9	5	22
16	16	M16x1,5	18	13	18	6	M5	12	19	M6	9	5	22
20	20	M22x1,5	20	14	24	8	G1/8	16	29	M8	12	7	24
25	22	M22x1,5	22	14	28	8	G1/8	16	32	M10x1,25	12	9	28

Double acting cylinders

Cyl. bore mm	XC mm	ZJ mm	P mm
10	64 + stroke	84 + stroke	46 + stroke
12	75 + stroke	99 + stroke	48 + stroke
16	82 + stroke	104 + stroke	53 + stroke
20	95 + stroke	125 + stroke	67 + stroke
25	104 + stroke	132 + stroke	68 + stroke

Single acting with spring return, type SS

Stroke/ Cyl. bore mm	10 mm	15 mm	25 mm	40 mm	50 mm	80 mm	10 mm	15 mm	25 mm	40 mm	50 mm	80 mm	10 mm	15 mm	25 mm	40 mm	50 mm	80 mm
	XC	XC	XC	XC	XC	XC	ZJ	ZJ	ZJ	ZJ	ZJ	ZJ	P	P	P	P	P	P
10	74	79	89	126	136	174	94	99	109	146	156	194	56	61	71	108	118	156
12	85	90	100	132	142	185	109	114	124	156	166	209	58	63	73	105	115	158
16	92	97	107	122	132	184	114	119	129	144	154	206	63	68	78	93	103	155
20	105	110	120	135	145	191	135	140	150	165	175	221	77	82	92	107	117	163
25	114	119	129	144	154	201	142	147	157	172	182	229	78	83	93	108	118	165

Length tolerances ±1 mm
 Stroke length tolerances +1,5/0 mm

Cylinders are supplied complete with mounting and adjusting nuts.
 Cylinders with through piston rod are supplied complete with two adjusting nuts and one mounting nut.

Cylinder mountings

Flange-MF8

Intended for fixed attachment of the cylinder. The flange is designed for mounting on the front or rear end-covers.

Material:
Stainless steel, DIN X 10 CrNiS 18 9

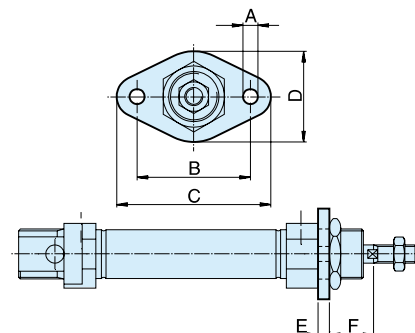

Cylinder Ø mm	A mm	B mm	C mm	D mm	E mm	F mm	Weight Kg	Order code
10	4,5	30	40	22	3	13	0,012	P1S-4CMB
12-16	5,5	40	52	30	4	18	0,025	P1S-4DMB
20	6,6	50	66	40	5	19	0,045	P1S-4HMB
25	6,6	50	66	40	5	23	0,045	P1S-4HMB

Foot-MS3

Intended for fixed attachment of the cylinder. The bracket is designed for mounting on the front or rear end-covers.

Material:
Stainless steel, DIN X 10 CrNiS 18 9

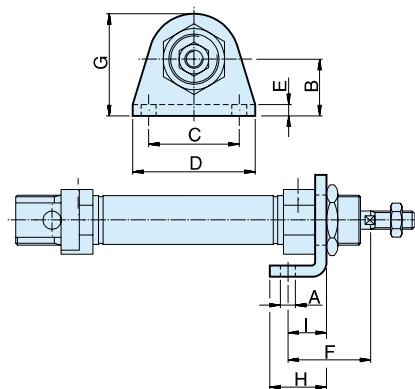

Cylinder Ø mm	A mm	B mm	C mm	D mm	E mm	F mm	G mm	H mm	I mm	Weight Kg	Order code
10	4,5	16	25	35	3	24	26	16	11	0,020	P1S-4CMF
12-16	5,5	20	32	42	4	32	32,5	20	14	0,040	P1S-4DMF
20	6,5	25	40	54	5	36	45	25	17	0,080	P1S-4HMF
25	6,5	25	40	54	5	40	45	25	17	0,080	P1S-4HMF

Cover trunnion

Intended for articulated mounting of the cylinder. The flange is designed for mounting on the front or rear end-covers.

Material:
Stainless steel, DIN X 10 CrNiS 18 9

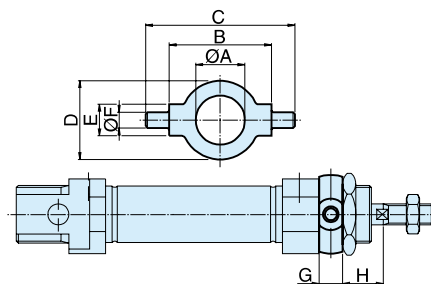

Cylinder Ø	A mm	B h14 mm	C mm	D mm	E e9 mm	F mm	G mm	H mm	Weight Kg	Order code
10	12,5	26	38	20	8	4	6	10	0,014	P1A-4CMJ
12-16	16,5	38	58	25	10	6	8	14	0,033	P1A-4DMJ
20	22,5	46	66	30	10	6	8	16	0,037	P1A-4HMJ
25	22,5	46	66	30	10	6	8	20	0,037	P1A-4HMJ

Mounting nut

Intended for fixed mounting of the cylinder. Cylinders are supplied complete with one mounting nut.

Material:
Stainless steel, DIN X 5 CrNi 18 10

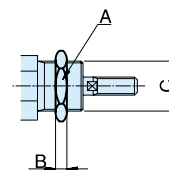

Cylinder Ø mm	A mm	B mm	C	Weight Kg	Order code
10	19	6	M12x1,25	0,009	9126725405
12-16	24	8	M16x1,50	0,018	9126725406
20-25	27	5	M22x1,50	0,042	9126725407

Cylinder mountings

Clevis bracket AB3



Intended for articulated mounting of the cylinder.
Supplied with shaft for mounting on the rear end cover.

Material:
Bracket: stainless steel, DIN X 5 CrNi 18 10
Pin: tempered stainless steel, DIN X 20 Cr 13
Locking rings: stainless steel, DIN X 5 CrNi 18 10

Cylinder Ø mm	A mm	B mm	C mm	D mm	E mm	F mm	G mm	H mm	I °	J °	Weight Kg	Order code
10	4,5	13	8	24	12,5	20	65,3	5	160	17	0,020	P1S-4CMT
12	5,5	18	12	27	15	25	73	7	170	15	0,040	P1S-4DMT
16	5,5	18	12	27	15	25	80	7	170	15	0,040	P1S-4DMT
20	6,5	24	16	30	20	32	91	10	165	10	0,080	P1S-4HMT
25	6,5	24	16	30	20	32	100	10	165	10	0,080	P1S-4HMT

S=stroke

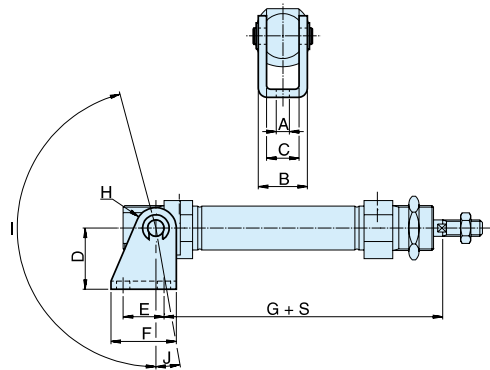

Clevis AP2



According to ISO 8140
Intended for articulated mounting of the cylinder.
This mounting is adjustable in the axial direction.
Supplied complete with pin.

Material:
Stainless steel, DIN X 5 CrNi 18 10

Cylinder Ø mm	A mm	B	C mm	D mm	E mm	F mm	G mm	H mm	I mm	J mm	Weight	Order code
10	4	M4	2,2	8	8	5	16	4	22	2	0,007	P1S-4CRD
12-16	6	M6	3,2	12	12	7	24	6	31	3	0,022	P1S-4DRD
20	8	M8	4	16	16	10	32	8	40,5	3,5	0,045	P1S-4HRD
25	10	M10x1,25	5	20	20	12	40	10	49	3	0,095	P1S-4JRD

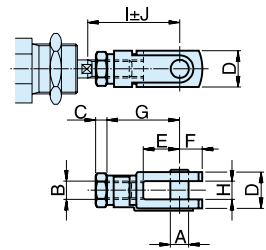

Swivel rod eye AP6



According to ISO 8139
Intended for articulated mounting of the cylinder.
This mounting is adjustable in the axial direction.

Material:
Swivel rod eye: stainless steel, DIN X 5 CrNi 18 10
Ball: hardened stainless steel, DIN X 5 CrNi 18 10

Cylinder Ø mm	A mm	B mm	C mm	D mm	E mm	F mm	G mm	H mm	I mm	J mm	K mm	L mm	Weight	Order code
10	5	M4	2,2	8	10	9	27	6	8	33	9	2	0,017	P1S-4CRT
12-16	6	M6	3,2	9	10	10	30	6,8	9	38,5	11	1,5	0,025	P1S-4DRT
20	8	M8	4	12	12	12	36	9	12	46	14	2	0,045	P1S-4HRT
25	10	M10x1,25	5	14	14	14	43	10,5	15	52,5	17	2,5	0,085	P1S-4JRT

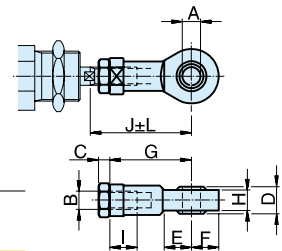

Rod nut



Intended for fixed mounting on the piston rod. Cylinders are supplied complete with one rod nut. (cylinders with through piston rod are supplied with two rod nuts.)

Material:
Stainless steel, DIN X 5 CrNi 18 10

Cylinder Ø mm	D	F mm	E mm	Weight	Order code
10	M4	7	2,2	0,001	9127385121
12-16	M6	10	3,2	0,002	9127385122
20	M8	13	4	0,005	9127385123
25	M10x1,25	17	5	0,007	9126725404

