



# Magnetically coupled pneumatic cylinder P1Z ...

**No leakage**, with high magnetic coupling force



The P1Z is a rodless pneumatic cylinder with piston and carriage equipped with ring magnets.

Motion is transmitted via the magnetic force locking between the piston and the carriage.

The guided version consists of a carriage fitted with 4 plain bearings, guided on 2 guide rods the design provides high rigidity, accurate guidance and a non rotating movement.

- Double acting with guide
- Magnetically coupled without mechanical connection
- Mechanical protection in case of occasional overload due to magnetic uncoupling
- Piston chamber and Slide are pressure tight
- Pressure tight and leak free system
- With adjustable pneumatic end cushioning on both sides
- Carriage is free to rotate 360° around the cylinder axis
- Air connection at one end (option)
- Position sensing: Al-profile rail for magnetic switches (option). Magnetic switches available as reed switches or as electronic sensors (option).
- Various mounting arrangements

## P1Z Series - Basic Version Ø 16-40 mm

The P1Z is a rodless pneumatic cylinder. The piston and the carriage are equipped with ring magnets. The motion is transmitted via the magnetic force locking between the piston and the carriage.

### Features:

- Double acting
- Magnetically coupled without mechanical connection
- Mechanical protection in case of occasional overload due to magnetic uncoupling
- Piston chamber and carriage are pressure tight
- Pressure tight and leak free system
- Dirt and dust cannot enter
- With adjustable pneumatic end cushioning on both sides
- Carriage is free to rotate 360° around the cylinder axis
- Various mounting arrangements

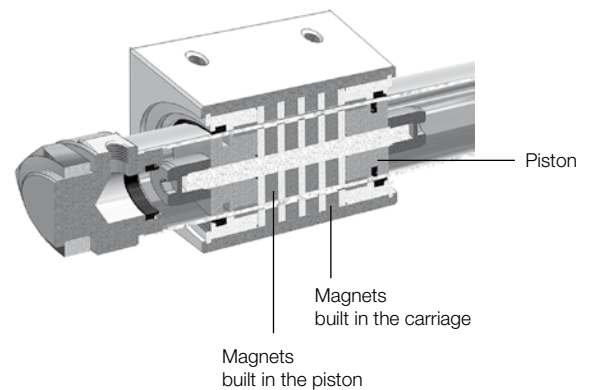
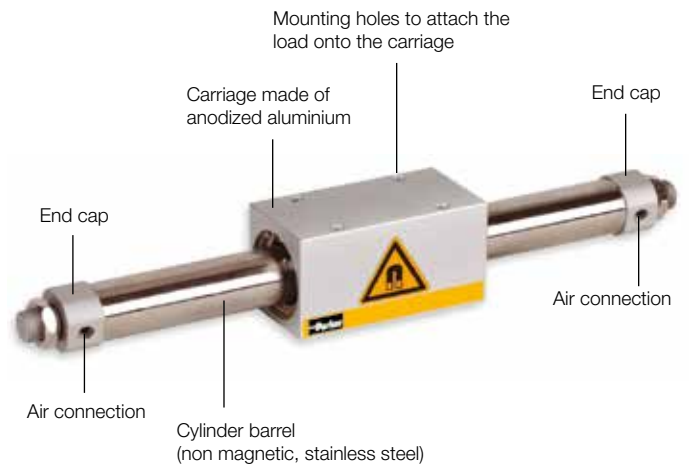

## Mounting and Technical Data Basic Version

- The loads can be fitted onto the carriage by 4 tapped holes.
- The cylinder is mounted at the end caps with hexagonal nuts, flange or foot mountings.

### Materials

Cylinder barrel	Stainless steel
Carriage	Al, anodised
End cap	Al, anodised
Seals	NBR



With 2 hexagonal nuts to fix the cylinder (included in scope of delivery)



Flange mounting (pair) option



Foot mounting (pair) option

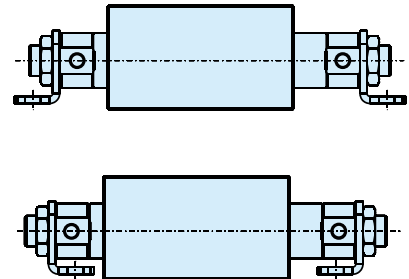
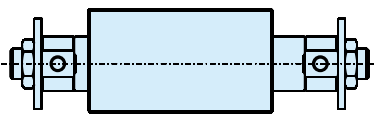

### Technical Data

Piston diameter Ø [mm]	16	20	25	32	40
Max. stroke length [mm]	1000	1500	2000	2000	2000
Stroke tolerance [mm] up to 1000 mm	0/+1.5				
Stroke tolerance [mm] > 1000 mm	0/+2				
Temperature range [°C]	0 to 60				
Operating medium	Filtered compressed air, dry, lubricated or unlubricated * (other media on request)				
Air supply port size	M5	G1/8	G1/8	G1/8	G1/4
Max. magnetic coupling force [N]	157	236	383	703	942
Velocity range [m/s]	0.1 to 1.3				
Min. operating pressure [bar]	1.8				
Max. operating pressure [bar]	6.5	7			
Cushion length [mm]	9	15	15	12	19
Weight [kg]					
at 0 mm stroke	0.28	0.46	0.83	1.35	2.01
per 100 mm stroke	0.043	0.082	0.088	0.14	0.16

\* if external lubrication is added, this must always be continued.

## Loads, forces and moments Basic Version

If the operating conditions are outside of the permissible values, either the P1Z guided version or the P1Z in combination with an external guide should be used !

### Forces [N]

Piston [mm]	16	20	25	32	40
Theoretical force at 6 bar [N]	120	188	295	483	754
Max. magnetic coupling force [N]	157	236	383	703	942

### Permissible lateral force, depending on the stroke length

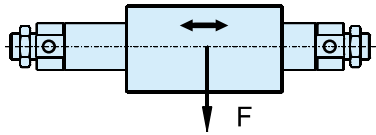

Ø [mm]	Permissible lateral force F [N]
16	30.0
20	50.0
25	70.0
32	100.0
40	165.0

The values are based on velocities  $v \leq 0.4\text{m/s}$

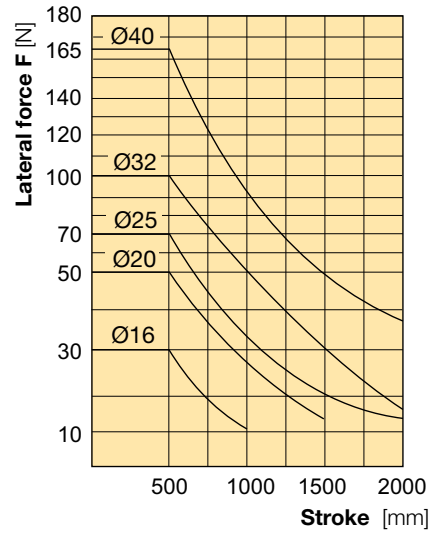

### Permissible axial load, horizontal mounting

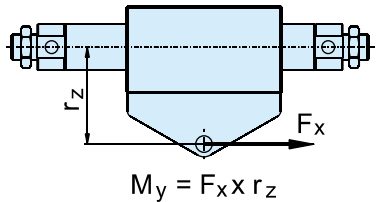

Ø [mm]	Max. Moment My [Nm]
16	1.2
20	2.5
25	3.8
32	8.5
40	13.0

### Permissible axial load, vertical mounting

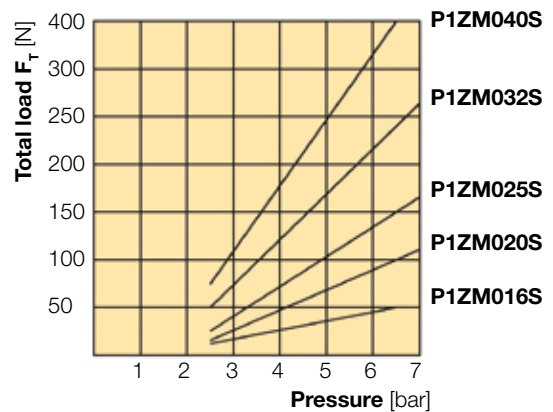
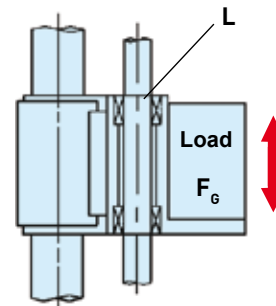

L = Weight of the external carriage  
 FG = Load  
 FT = Total load = Load FG + Weight of the external carriage L + Force due to friction



**Dynamic forces must not exceed the maximum magnetic coupling force!**

### Cushioning diagram

If the permitted limit values are exceeded, additional shock absorbers should be fitted in the area of the centre of gravity.

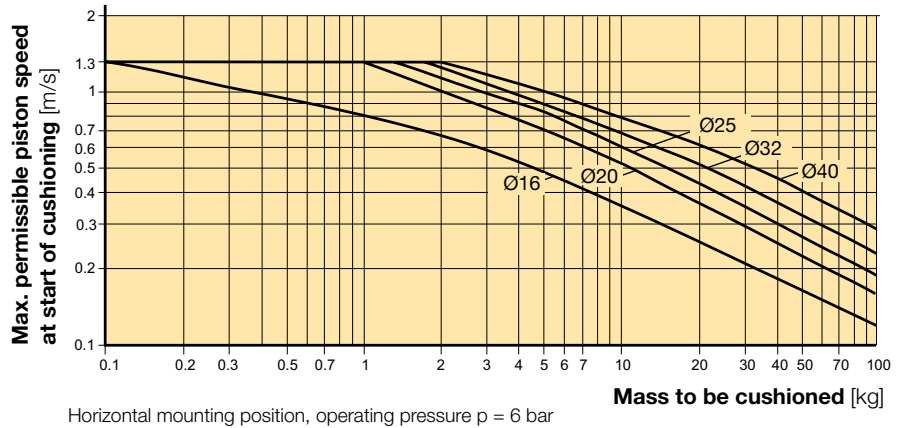

### Installation tips for use with external guides

When stopping a load having a large inertia force at the stroke end, tilting of the carriage and damage to the bearings and cylinder barrel may occur (fig. left).

To prevent this, the force transmission should be realized at the middle axis of the cylinder.

The combination of the shock absorber with an end stop, can help to prevent the tilting of the carriage (fig. right).

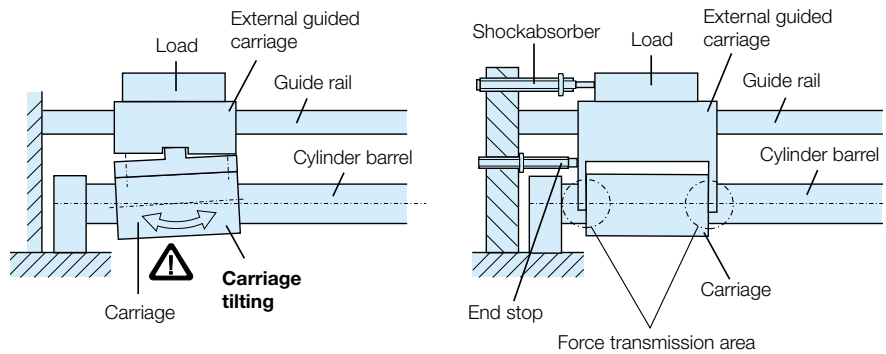

Order Instructions - Basic Cylinder - Series P1Z

Basic cylinder (15 digits)													With option (18 digits)				
<b>P</b>	<b>1</b>	<b>Z</b>	<b>M</b>	<b>0</b>	<b>1</b>	<b>6</b>	<b>S</b>	<b>A</b>	<b>N</b>	<b>0</b>	<b>8</b>	<b>5</b>	<b>0</b>	<b>W</b>	<b>F</b>	<b>M</b>	<b>N</b>

Piston diameter	
<b>016</b>	Ø 16 mm
<b>020</b>	Ø 20 mm
<b>025</b>	Ø 25 mm
<b>032</b>	Ø 32 mm
<b>040</b>	Ø 40 mm

End of stroke cushioning	
<b>A</b>	Pneumatically adjustable (Ø 16, 20, 25, 32 and 40 mm)

Stroke length	
max. stroke [mm]	Piston Ø [mm]
<b>1000</b>	Ø 16
<b>1500</b>	Ø 20
<b>2000</b>	Ø 25
<b>2000</b>	Ø 32
<b>2000</b>	Ø 40

Options	
<b>B</b>	without
<b>W</b>	with

Mountings	
<b>N</b>	without
<b>F</b>	Foot mounting
<b>L</b>	Flange mounting

Air supply port type	
<b>M</b>	Metric thread (Ø 16 mm)
<b>B</b>	G-thread (Ø 20 - 40 mm)
(Other types on request)	

**Order code examples:**

- **P1ZM016SAN0100B**      Ø 16 mm, stroke 100 mm, supplied with hexagonal nuts on each end cap.
- **P1ZM020SAN1000WFBN**      Ø 20 mm, stroke 1000 mm, with foot mounting at both end caps.

For further technical information see catalogue P-A4P019GB

## P1Z Series - Guided Version

### Ø 16-40 mm

The P1Z is a rodless pneumatic cylinder with guide. The piston and the guide carriage are equipped with ring magnets.

The motion is transmitted via the magnetic force between the piston and the guide carriage.

The guided version consists of a carriage fitted with 4 plain bearings, guided on 2 guide rods. The design provides high rigidity, accurate guidance and a non rotating movement.

#### Features:

- Double acting with guide
- Magnetically coupled without mechanical connection
- Mechanical protection in case of occasional overload due to magnetic uncoupling
- Piston chamber and Slide are pressure tight
- Pressure tight and leak free system
- Air connection at one end (option)
- End of stroke cushioning: with elastomeric bumpers (standard), with hydraulic shock absorbers (option)
- Position sensing: AI-profile rail for magnetic switches (option). Magnetic switches available as reed switches or as electronic sensors (option).

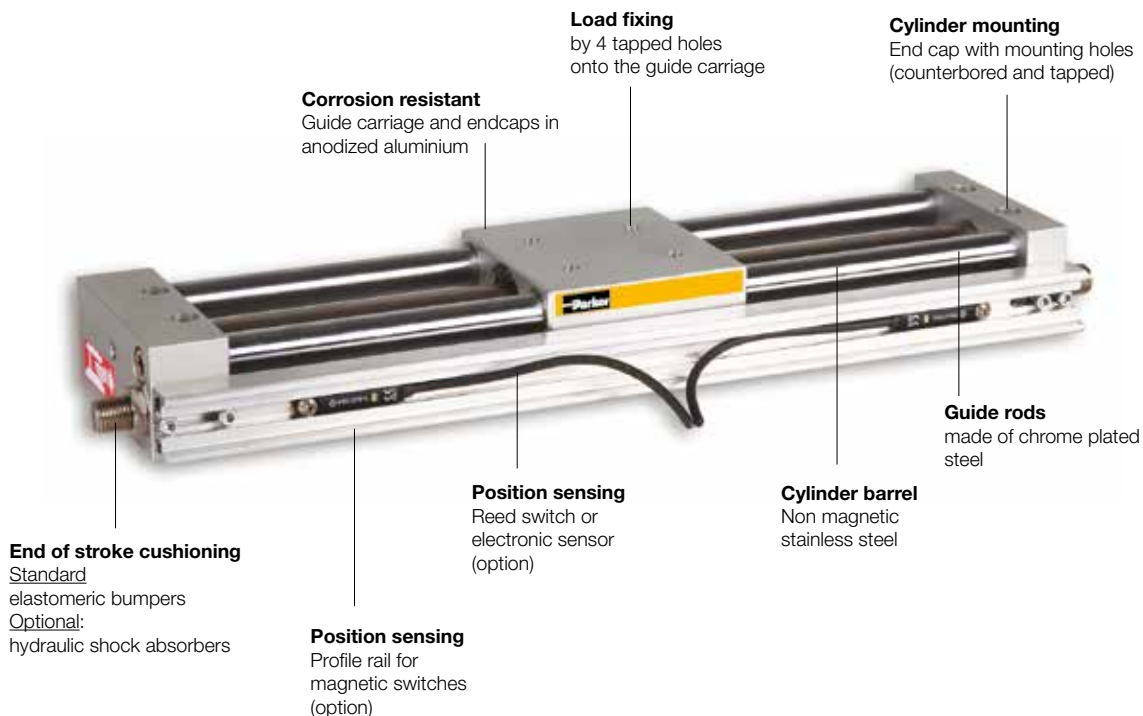
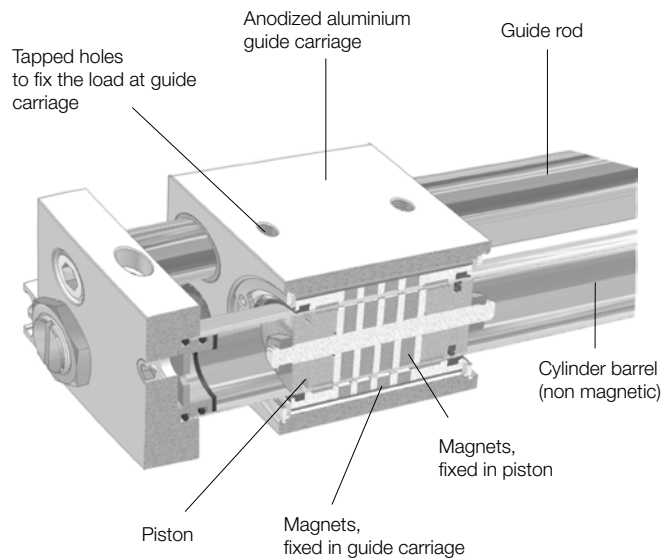

**Guided Version  
 Ø 16 - 40 mm**

**Air connection**



Guided version P1Z and air connection on both sides (standard)



Guided version P1Z and air connection at one end (option)

**End of stroke cushioning**

The end of stroke cushioning for light loads is provided by elastomeric bumpers (standard).

For medium and heavy loads hydraulic shock absorbers should be used (option).



Guided version P1Z and elastomeric bumpers (standard)



Guided version P1Z and hydraulic shock absorbers (option)

**Position sensing**

The guide carriage is fitted with a magnet for position sensing (standard)

An Al-profile rail for magnetic switches is available as an option. The rail is located on the same side as the elastomeric bumpers or the shock absorbers.

Reed switches or electronic sensors in several versions can be moved in the profile rail along the entire stroke length.



Guided version P1Z with magnet in the guide carriage for position sensing (standard).



Guided version P1Z and Al-profile rail for magnetic switches (option).



Guided version P1Z and Al-profile rail with 2 magnetic switches (option).



## Mounting and Technical Data

### Guided Version

The loads can be fixed onto the guide carriage by 4 tapped holes.

Cylinder mounting provided with 4 tapped and counterbored holes. Additional mountings are not required.

#### Materials

Cylinder barrel	Stainless steel
Carriage	Al, anodised
End cap	Al, anodised
Seals	NBR
Guide rods	Steel, chrome plated

#### Technical Data

Piston diameter Ø [mm]	16	20	25	32	40
Max. stroke length [mm]	750	1000	1500	1500	1500
Stroke tolerance [mm] up to 1000 mm	0/+1.5				
Stroke tolerance [mm] > 1000 mm	0/+2				
Temperature range [°C]	0 to 60				
Operating medium	Filtered compressed air, dry, lubricated or unlubricated * (other media on request)				
Air supply port size	M5	G1/8	G1/8	G1/8	G1/4
Max. magnetic coupling force [N]	157	236	383	703	942
Velocity range [m/s]	0.5 to 0.4				
Min. operating pressure [bar]	2.3	2			
Max. operating pressure [bar]	6.5	7			
Weight [kg]					
at 0 mm stroke	0.9	1.52	1.70	3.63	5.44
per 100 mm stroke	0.2	0.33	0.42	0.53	0.86

\* if external lubrication is added, this must always be continued.

**Loads, forces and moments  
 Guided Version**

**Forces [N]**

Piston [mm]	16	20	25	32	40
Theoretical force at 6 bar [N]	120	188	295	483	754
Max. magnetic coupling force [N]	157	236	383	703	942

**Permissible lateral force, depending on the stroke length**

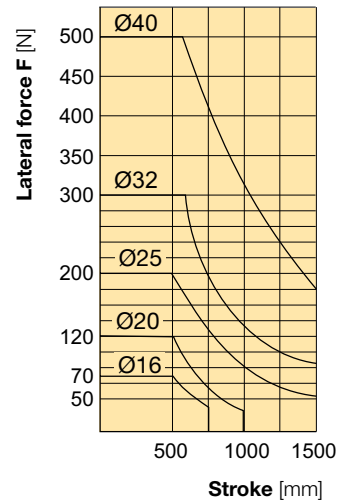
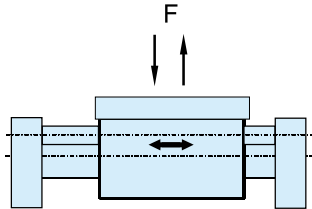

Ø [mm]	Max. Moment $M_x$ [Nm]	Max. Moment $M_y$ [Nm]	Max. Moment $M_z$ [Nm]
16	0.5	2.4	2.4
20	1.0	5.0	5.0
25	1.8	9.5	9.5
32	3.0	15.0	15.0
40	4.5	24.0	24.0

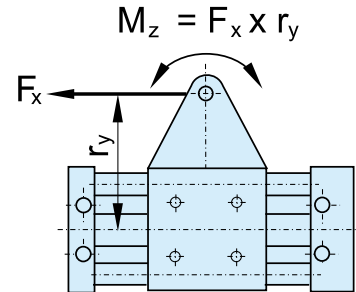
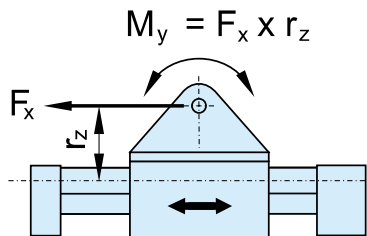
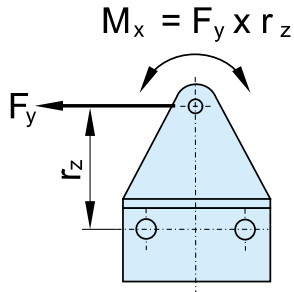

**Permissible moment  $M_x$  depending on the stroke length**

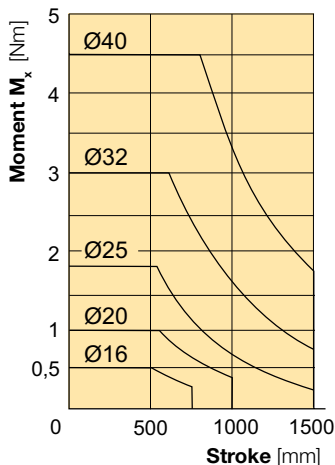

**Dynamic forces must not exceed the maximum magnetic coupling force!**

Permissible axial load, vertical mounting

For vertical applications please refer to the values in the diagrams !

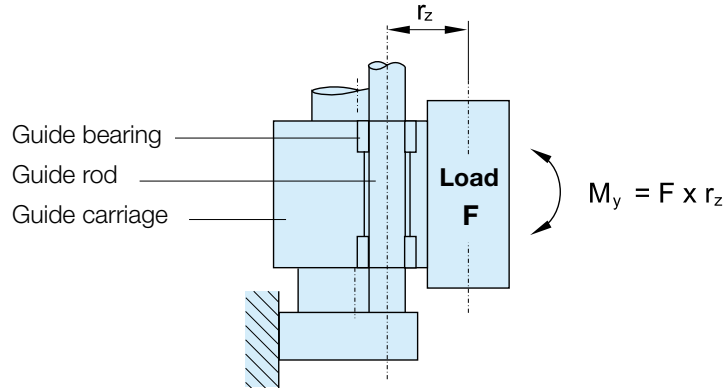

Cylinder Ø 16, 25, 40

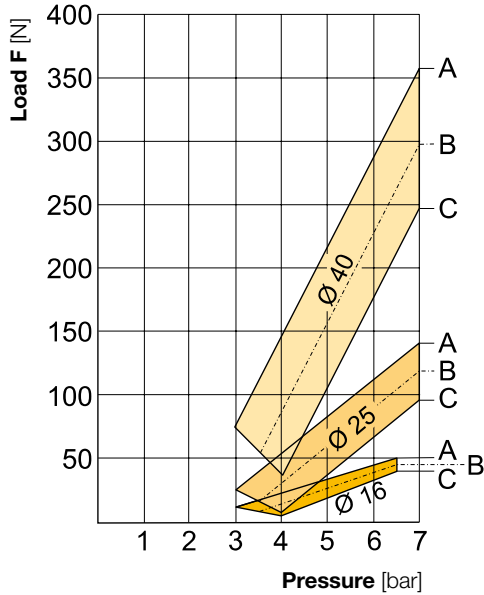

Cylinder Ø 20, 32

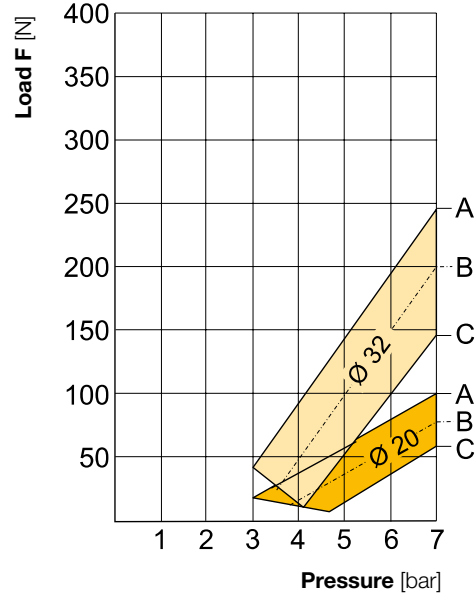

Ø [mm]	Max. Load F [N]	B Max. Moment $M_y / 2$ [Nm]	C Max. Moment $M_y$ [Nm]
16	50.0	1.2	2.4
20	100.0	2.5	5.0
25	140.0	4.75	9.5
32	240.0	7.5	15.0
40	360.0	12.0	24.0

A = curve at moment  $M_y = 0$

B = curve at moment  $M_y/2 =$  see column B

C = curve at moment  $M_{y,max.} =$  see column C

Order Instructions - Guided version

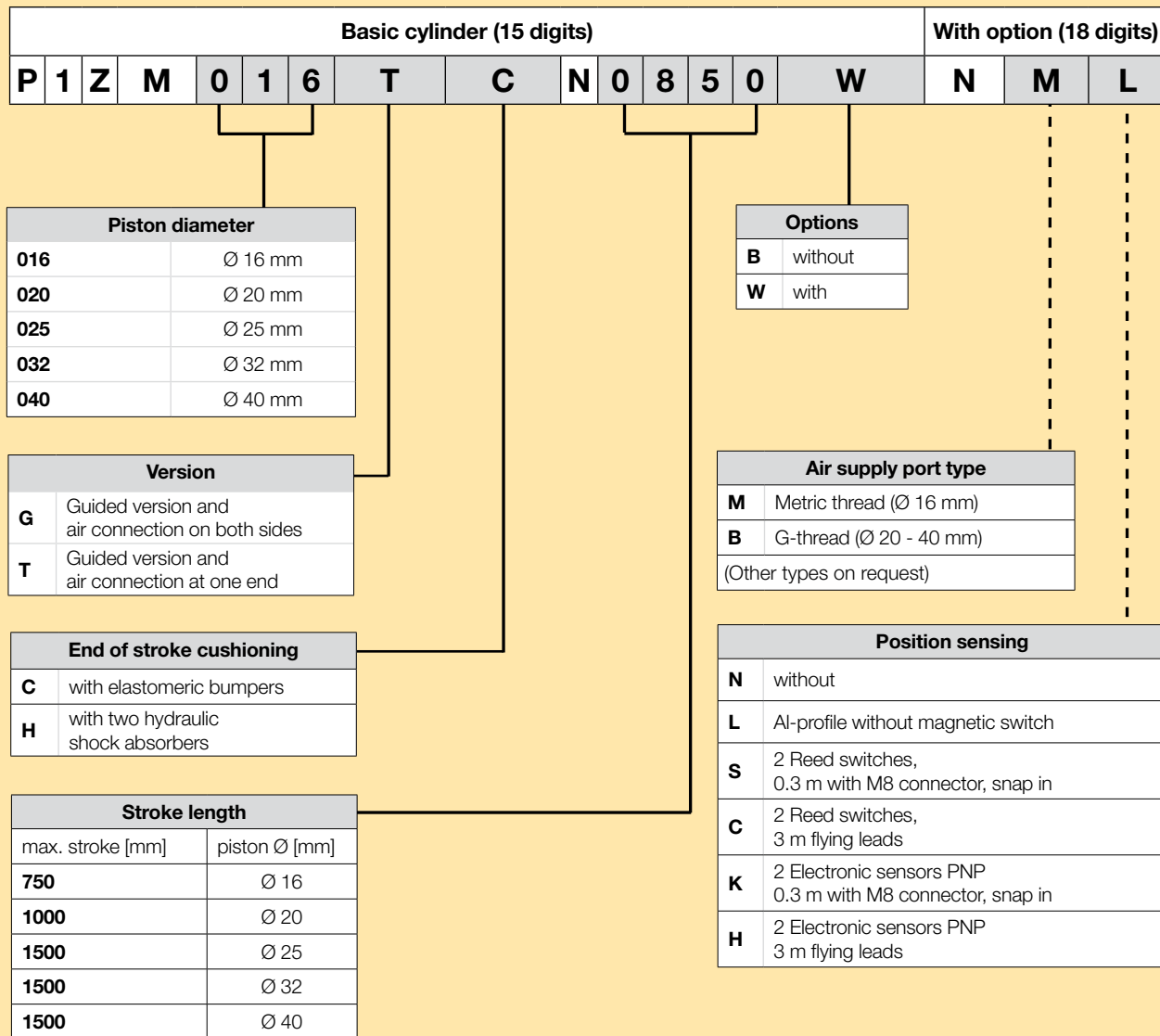

Order code examples:

- **P1ZM016TCN0100B**      Cylinder guided version -Ø 16 mm, stroke 100 mm, with air connection at one end and elastomeric bumpers.
  
- **P1ZM020GHN1000WNBL**      Cylinder guided version -Ø 20 mm, stroke 1000 mm, with air connection on both sides, with two hydraulic shock absorbers and profile rail for magnetic switches.

For further technical information see catalogue P-A4P019GB

Cylinder bore mm	Series		Stroke	Bore mm	Piston rod mm	Area cm <sup>2</sup>	Max theoretical force in N									
							1.0 bar	2.0 bar	3.0 bar	4.0 bar	5.0 bar	6.0 bar	7.0 bar	8.0 bar	9.0 bar	10.0 bar
10/4	P1A P1S	Double acting	+	10	4	0.8	8	15	23	31	39	46	54	62	69	77
			-	10	4	0.7	6	13	19	26	32	39	45	52	58	65
12/5	C05	Double acting	+	12	5	1.1	11	22	33	44	55	67	78	89	100	111
			-	12	5	0.9	9	18	28	37	46	55	64	73	83	92
12/6	P1A P1Q P1S	Double acting	+	12	6	1.1	11	22	33	44	55	67	78	89	100	111
			-	12	6	0.8	8	17	25	33	42	50	58	67	75	83
16/6	P1A P1S	Double acting	+	16	6	2.0	20	39	59	79	99	118	138	158	178	197
			-	16	6	1.7	17	34	51	68	85	102	119	136	153	170
16/8	P1Q	Double acting	+	16	8	2.0	20	39	59	79	99	118	138	158	178	197
			-	16	8	1.5	15	30	44	59	74	89	104	118	133	148
20/8	P1A P1S	Double acting	+	20	8	3.1	31	62	92	123	154	185	216	247	277	308
			-	20	8	2.6	26	52	78	104	129	155	181	207	233	259
20/10	C05 P1Q P5T	Double acting	+	20	10	3.1	31	62	92	123	154	185	216	247	277	308
			-	20	10	2.4	23	46	69	92	116	139	162	185	208	231
25/10	P1A P1Q P1S P5T	Double acting	+	25	10	4.9	48	96	144	193	241	289	337	385	433	482
			-	25	10	4.1	40	81	121	162	202	243	283	324	364	405
32/12	C05 P1D P1P P1Q P1S P1D-B P1D-C P1D-X	Double acting	+	32	12	8.0	79	158	237	316	394	473	552	631	710	789
			-	32	12	6.9	68	136	203	271	339	407	475	542	610	678
			+	32	12	8.0	80	161	241	322	402	483	563	643	724	804
			-	32	12	6.9	69	138	207	276	346	415	484	553	622	691
			+	32	12	8.0	80	161	241	322	402	483	563	643	724	804
			-	32	12	6.9	69	138	207	276	346	415	484	553	622	691
32/16	P5T	Double acting	+	32	16	8.0	79	158	237	316	394	473	552	631	710	789
			-	32	16	6.0	59	118	178	237	296	355	414	473	533	592
40/16	P1D P1D-C	Double acting	+	40	16	12,6	126	251	377	503	628	754	880	1005	1131	1257
			-	40	16	10,6	106	212	318	424	530	636	742	848	954	1060
40/12	P1P	Double acting	+	40	12	12,6	123	247	370	493	616	740	863	986	1109	1233
			-	40	12	11,4	112	224	337	449	561	673	785	897	1010	1122
40/16	P1Q P1D-B P1D-C P1D-X	Double acting	+	40	16	12,6	123	247	370	493	616	740	863	986	1109	1233
			-	40	16	10,6	104	207	311	414	518	621	725	828	932	1036
			+	40	16	12,6	126	251	377	503	628	754	880	1005	1131	1257
			-	40	16	10,6	106	212	318	424	530	636	742	848	954	1060
50/16	C05 P1P	Double acting	+	50	16	19,6	193	385	578	770	963	1156	1348	1541	1734	1926
			-	50	16	17,6	173	346	519	692	865	1037	1210	1383	1556	1729
50/20	P1D P1Q P1S P5T P1D-B P1D-C P1D-X	Double acting	+	50	20	19,6	193	385	578	770	963	1156	1348	1541	1734	1926
			-	50	20	16,5	162	324	485	647	809	971	1133	1295	1456	1618
			+	50	20	19,6	196	393	589	785	982	1178	1374	1571	1767	1963
			-	50	20	16,5	165	330	495	660	825	990	1155	1319	1484	1649



# Magnetically coupled pneumatic cylinder P1Z ...

**No leakage**, with high magnetic coupling force



The P1Z is a rodless pneumatic cylinder with piston and carriage equipped with ring magnets.

Motion is transmitted via the magnetic force locking between the piston and the carriage.

The guided version consists of a carriage fitted with 4 plain bearings, guided on 2 guide rods the design provides high rigidity, accurate guidance and a non rotating movement.

- Double acting with guide
- Magnetically coupled without mechanical connection
- Mechanical protection in case of occasional overload due to magnetic uncoupling
- Piston chamber and Slide are pressure tight
- Pressure tight and leak free system
- With adjustable pneumatic end cushioning on both sides
- Carriage is free to rotate 360° around the cylinder axis
- Air connection at one end (option)
- Position sensing: Al-profile rail for magnetic switches (option). Magnetic switches available as reed switches or as electronic sensors (option).
- Various mounting arrangements

## P1Z Series - Basic Version Ø 16-40 mm

The P1Z is a rodless pneumatic cylinder. The piston and the carriage are equipped with ring magnets. The motion is transmitted via the magnetic force locking between the piston and the carriage.

### Features:

- Double acting
- Magnetically coupled without mechanical connection
- Mechanical protection in case of occasional overload due to magnetic uncoupling
- Piston chamber and carriage are pressure tight
- Pressure tight and leak free system
- Dirt and dust cannot enter
- With adjustable pneumatic end cushioning on both sides
- Carriage is free to rotate 360° around the cylinder axis
- Various mounting arrangements

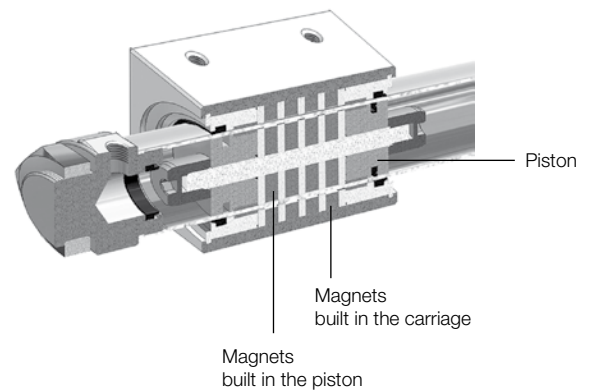
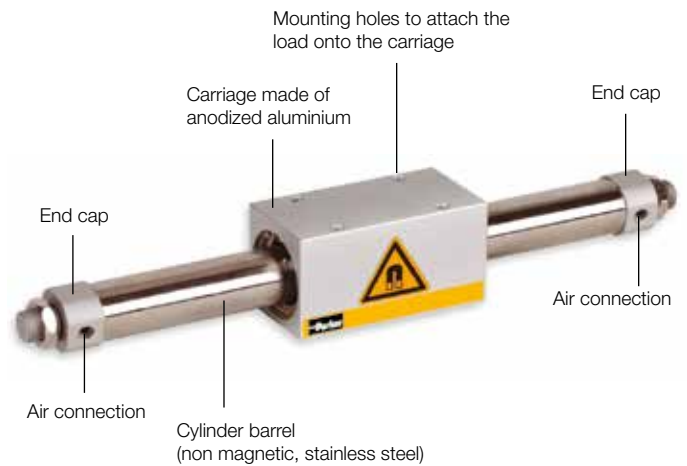

## Mounting and Technical Data Basic Version

- The loads can be fitted onto the carriage by 4 tapped holes.
- The cylinder is mounted at the end caps with hexagonal nuts, flange or foot mountings.

### Materials

Cylinder barrel	Stainless steel
Carriage	Al, anodised
End cap	Al, anodised
Seals	NBR



With 2 hexagonal nuts to fix the cylinder (included in scope of delivery)



Flange mounting (pair) option



Foot mounting (pair) option

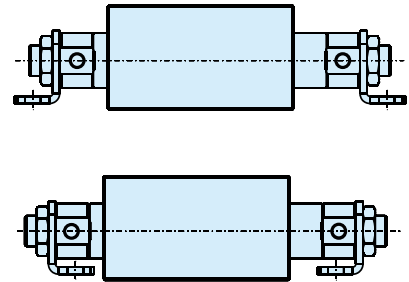
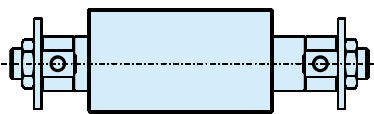

### Technical Data

Piston diameter Ø [mm]	16	20	25	32	40
Max. stroke length [mm]	1000	1500	2000	2000	2000
Stroke tolerance [mm] up to 1000 mm	0/+1.5				
Stroke tolerance [mm] > 1000 mm	0/+2				
Temperature range [°C]	0 to 60				
Operating medium	Filtered compressed air, dry, lubricated or unlubricated * (other media on request)				
Air supply port size	M5	G1/8	G1/8	G1/8	G1/4
Max. magnetic coupling force [N]	157	236	383	703	942
Velocity range [m/s]	0.1 to 1.3				
Min. operating pressure [bar]	1.8				
Max. operating pressure [bar]	6.5	7			
Cushion length [mm]	9	15	15	12	19
Weight [kg]					
at 0 mm stroke	0.28	0.46	0.83	1.35	2.01
per 100 mm stroke	0.043	0.082	0.088	0.14	0.16

\* if external lubrication is added, this must always be continued.



## Loads, forces and moments Basic Version

If the operating conditions are outside of the permissible values, either the P1Z guided version or the P1Z in combination with an external guide should be used !

### Forces [N]

Piston [mm]	16	20	25	32	40
Theoretical force at 6 bar [N]	120	188	295	483	754
Max. magnetic coupling force [N]	157	236	383	703	942

### Permissible lateral force, depending on the stroke length

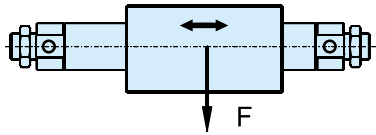

Ø [mm]	Permissible lateral force F [N]
16	30.0
20	50.0
25	70.0
32	100.0
40	165.0

The values are based on velocities  $v \leq 0.4\text{m/s}$

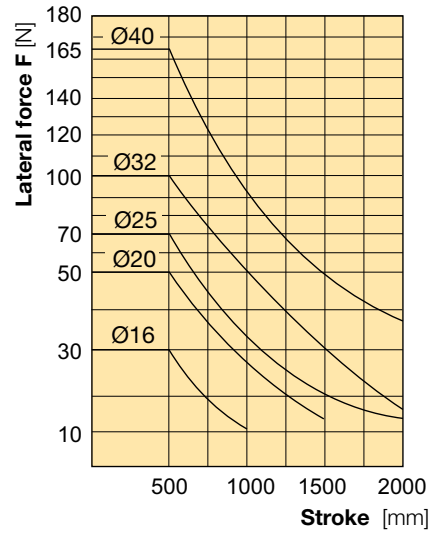

### Permissible axial load, horizontal mounting

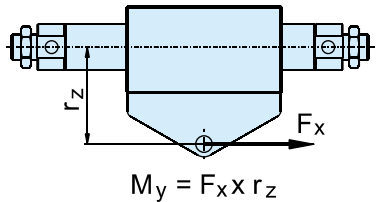

Ø [mm]	Max. Moment $M_y$ [Nm]
16	1.2
20	2.5
25	3.8
32	8.5
40	13.0

### Permissible axial load, vertical mounting

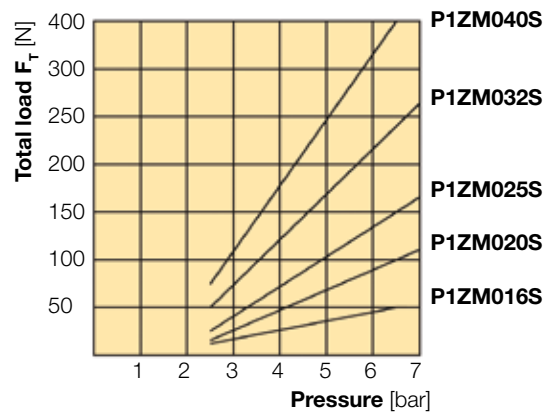
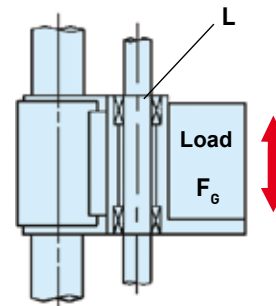

$L$  = Weight of the external carriage  
 $F_G$  = Load  
 $F_T$  = Total load = Load  $F_G$  + Weight of the external carriage  $L$  + Force due to friction



**Dynamic forces must not exceed the maximum magnetic coupling force!**

### Cushioning diagram

If the permitted limit values are exceeded, additional shock absorbers should be fitted in the area of the centre of gravity.

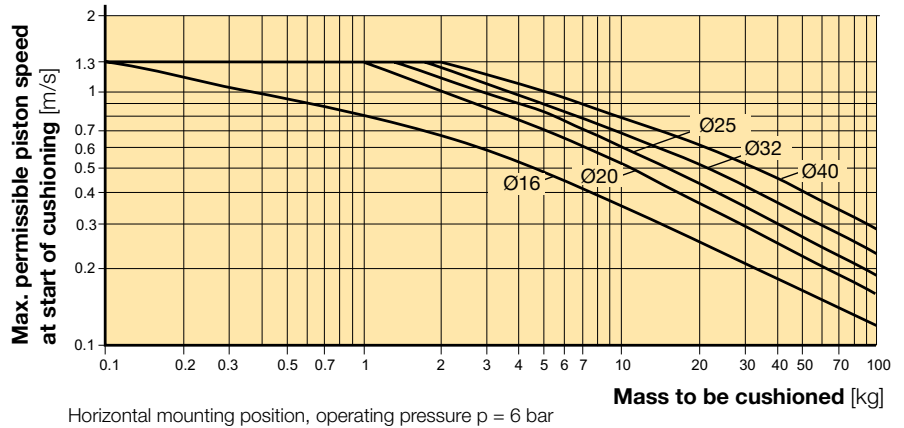

### Installation tips for use with external guides

When stopping a load having a large inertia force at the stroke end, tilting of the carriage and damage to the bearings and cylinder barrel may occur (fig. left).

To prevent this, the force transmission should be realized at the middle axis of the cylinder.

The combination of the shock absorber with an end stop, can help to prevent the tilting of the carriage (fig. right).

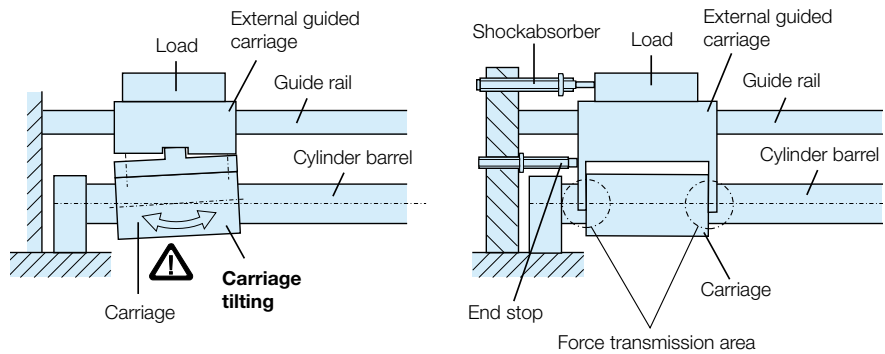

Order Instructions - Basic Cylinder - Series P1Z

Basic cylinder (15 digits)													With option (18 digits)				
<b>P</b>	<b>1</b>	<b>Z</b>	<b>M</b>	<b>0</b>	<b>1</b>	<b>6</b>	<b>S</b>	<b>A</b>	<b>N</b>	<b>0</b>	<b>8</b>	<b>5</b>	<b>0</b>	<b>W</b>	<b>F</b>	<b>M</b>	<b>N</b>

Piston diameter	
<b>016</b>	Ø 16 mm
<b>020</b>	Ø 20 mm
<b>025</b>	Ø 25 mm
<b>032</b>	Ø 32 mm
<b>040</b>	Ø 40 mm

End of stroke cushioning	
<b>A</b>	Pneumatically adjustable (Ø 16, 20, 25, 32 and 40 mm)

Stroke length	
max. stroke [mm]	Piston Ø [mm]
<b>1000</b>	Ø 16
<b>1500</b>	Ø 20
<b>2000</b>	Ø 25
<b>2000</b>	Ø 32
<b>2000</b>	Ø 40

Options	
<b>B</b>	without
<b>W</b>	with

Mountings	
<b>N</b>	without
<b>F</b>	Foot mounting
<b>L</b>	Flange mounting

Air supply port type	
<b>M</b>	Metric thread (Ø 16 mm)
<b>B</b>	G-thread (Ø 20 - 40 mm)
(Other types on request)	

**Order code examples:**

- **P1ZM016SAN0100B**      Ø 16 mm, stroke 100 mm, supplied with hexagonal nuts on each end cap.
- **P1ZM020SAN1000WFBN**      Ø 20 mm, stroke 1000 mm, with foot mounting at both end caps.

For further technical information see catalogue P-A4P019GB

## P1Z Series - Guided Version

### Ø 16-40 mm

The P1Z is a rodless pneumatic cylinder with guide. The piston and the guide carriage are equipped with ring magnets.

The motion is transmitted via the magnetic force between the piston and the guide carriage.

The guided version consists of a carriage fitted with 4 plain bearings, guided on 2 guide rods. The design provides high rigidity, accurate guidance and a non rotating movement.

#### Features:

- Double acting with guide
- Magnetically coupled without mechanical connection
- Mechanical protection in case of occasional overload due to magnetic uncoupling
- Piston chamber and Slide are pressure tight
- Pressure tight and leak free system
- Air connection at one end (option)
- End of stroke cushioning: with elastomeric bumpers (standard), with hydraulic shock absorbers (option)
- Position sensing: AI-profile rail for magnetic switches (option). Magnetic switches available as reed switches or as electronic sensors (option).

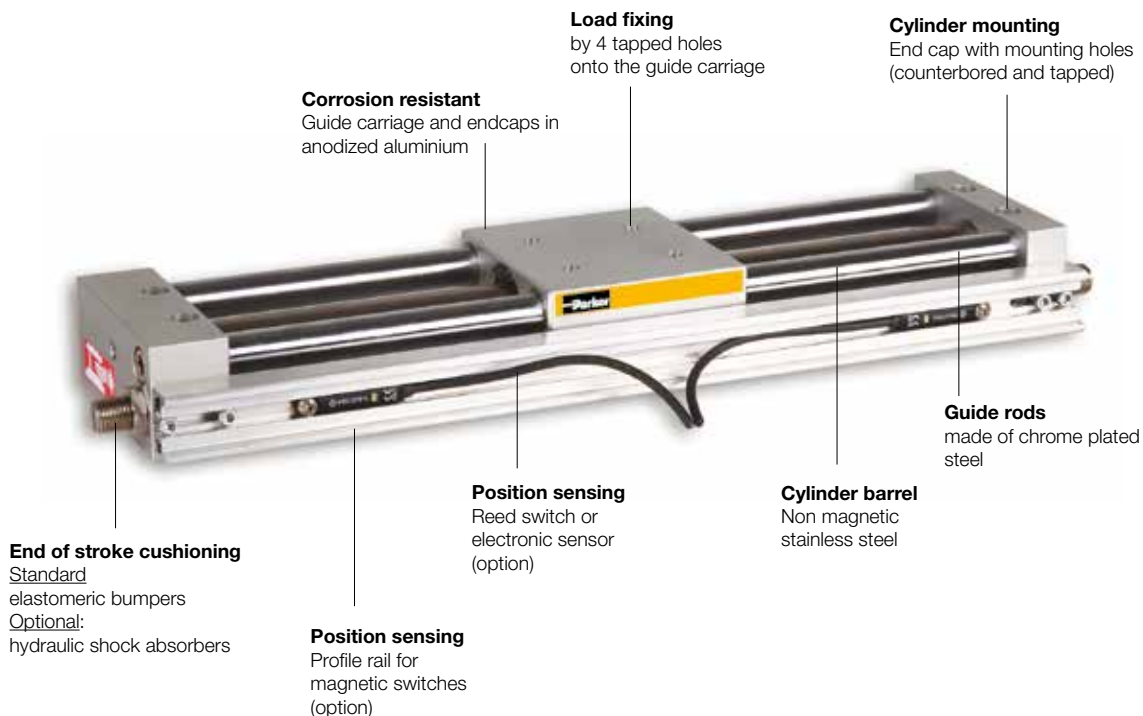
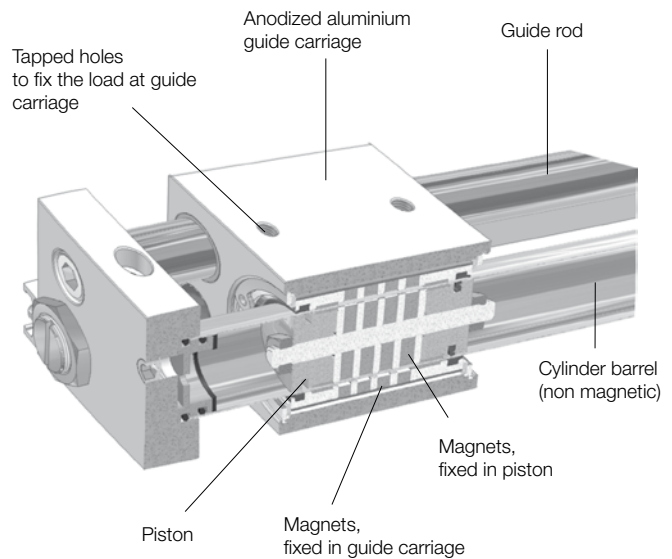

**Guided Version  
 Ø 16 - 40 mm**

**Air connection**



Guided version P1Z and air connection on both sides (standard)



Guided version P1Z and air connection at one end (option)

**End of stroke cushioning**

The end of stroke cushioning for light loads is provided by elastomeric bumpers (standard).

For medium and heavy loads hydraulic shock absorbers should be used (option).



Guided version P1Z and elastomeric bumpers (standard)



Guided version P1Z and hydraulic shock absorbers (option)

**Position sensing**

The guide carriage is fitted with a magnet for position sensing (standard)

An Al-profile rail for magnetic switches is available as an option. The rail is located on the same side as the elastomeric bumpers or the shock absorbers.

Reed switches or electronic sensors in several versions can be moved in the profile rail along the entire stroke length.



Guided version P1Z with magnet in the guide carriage for position sensing (standard).



Guided version P1Z and Al-profile rail for magnetic switches (option).



Guided version P1Z and Al-profile rail with 2 magnetic switches (option).

## Mounting and Technical Data

### Guided Version

The loads can be fixed onto the guide carriage by 4 tapped holes.

Cylinder mounting provided with 4 tapped and counterbored holes. Additional mountings are not required.

#### Materials

Cylinder barrel	Stainless steel
Carriage	Al, anodised
End cap	Al, anodised
Seals	NBR
Guide rods	Steel, chrome plated

#### Technical Data

Piston diameter Ø [mm]	16	20	25	32	40
Max. stroke length [mm]	750	1000	1500	1500	1500
Stroke tolerance [mm] up to 1000 mm	0/+1.5				
Stroke tolerance [mm] > 1000 mm	0/+2				
Temperature range [°C]	0 to 60				
Operating medium	Filtered compressed air, dry, lubricated or unlubricated * (other media on request)				
Air supply port size	M5	G1/8	G1/8	G1/8	G1/4
Max. magnetic coupling force [N]	157	236	383	703	942
Velocity range [m/s]	0.5 to 0.4				
Min. operating pressure [bar]	2.3	2			
Max. operating pressure [bar]	6.5	7			
Weight [kg]					
at 0 mm stroke	0.9	1.52	1.70	3.63	5.44
per 100 mm stroke	0.2	0.33	0.42	0.53	0.86

\* if external lubrication is added, this must always be continued.

**Loads, forces and moments  
 Guided Version**

**Forces [N]**

Piston [mm]	16	20	25	32	40
Theoretical force at 6 bar [N]	120	188	295	483	754
Max. magnetic coupling force [N]	157	236	383	703	942

**Permissible lateral force, depending on the stroke length**

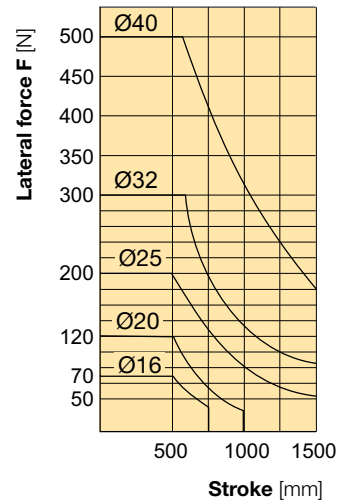
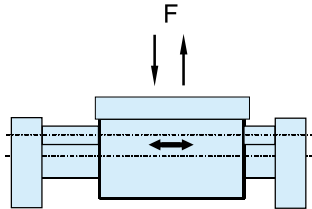

Ø [mm]	Max. Moment $M_x$ [Nm]	Max. Moment $M_y$ [Nm]	Max. Moment $M_z$ [Nm]
16	0.5	2.4	2.4
20	1.0	5.0	5.0
25	1.8	9.5	9.5
32	3.0	15.0	15.0
40	4.5	24.0	24.0

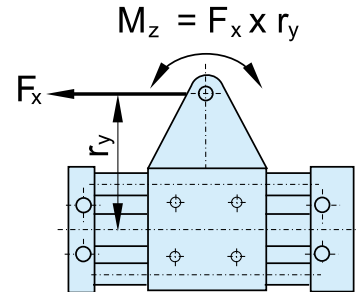
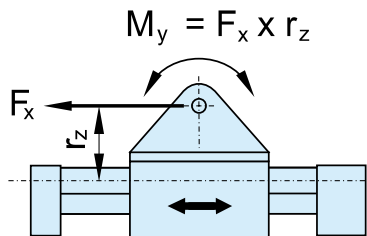
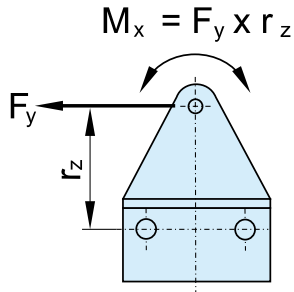

**Permissible moment  $M_x$  depending on the stroke length**

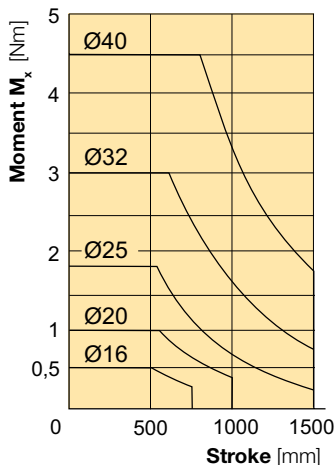

**Dynamic forces must not exceed the maximum magnetic coupling force!**

Permissible axial load, vertical mounting

For vertical applications please refer to the values in the diagrams !

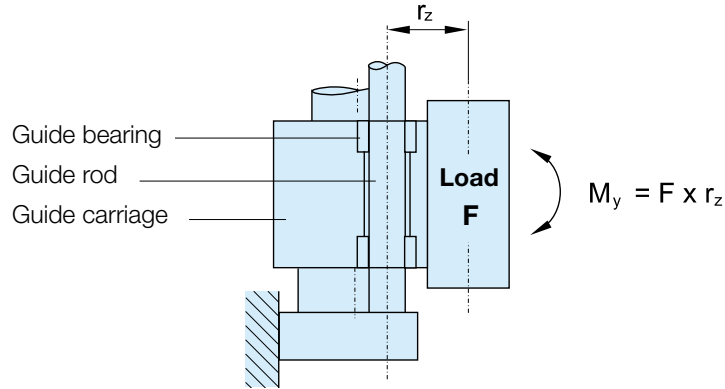

Cylinder Ø 16, 25, 40

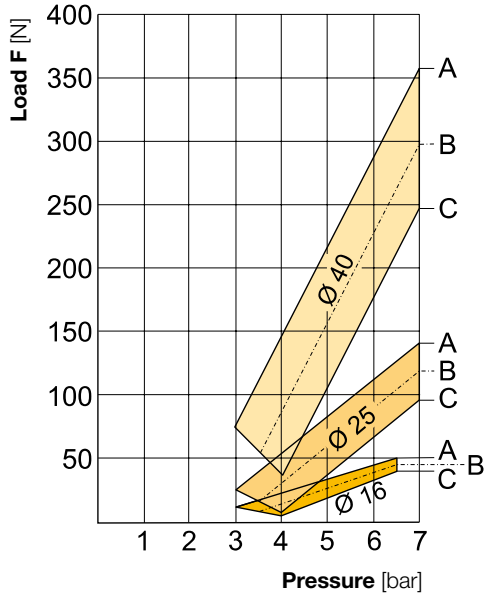

Cylinder Ø 20, 32

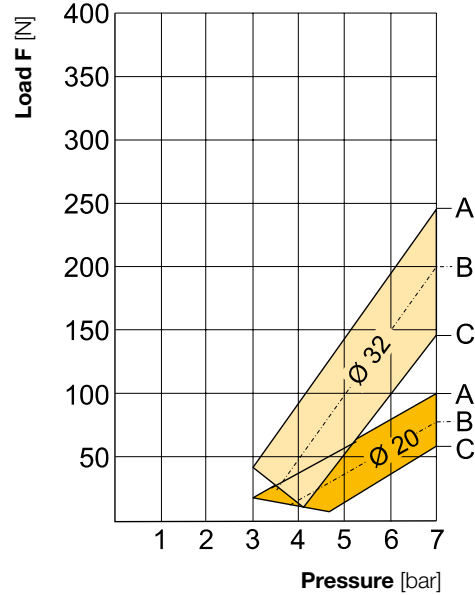

Ø [mm]	Max. Load F [N]	B Max. Moment $M_y / 2$ [Nm]	C Max. Moment $M_y$ [Nm]
16	50.0	1.2	2.4
20	100.0	2.5	5.0
25	140.0	4.75	9.5
32	240.0	7.5	15.0
40	360.0	12.0	24.0

A = curve at moment  $M_y = 0$

B = curve at moment  $M_y/2 =$  see column B

C = curve at moment  $M_{y_{max.}}$  = see column C



Order Instructions - Guided version

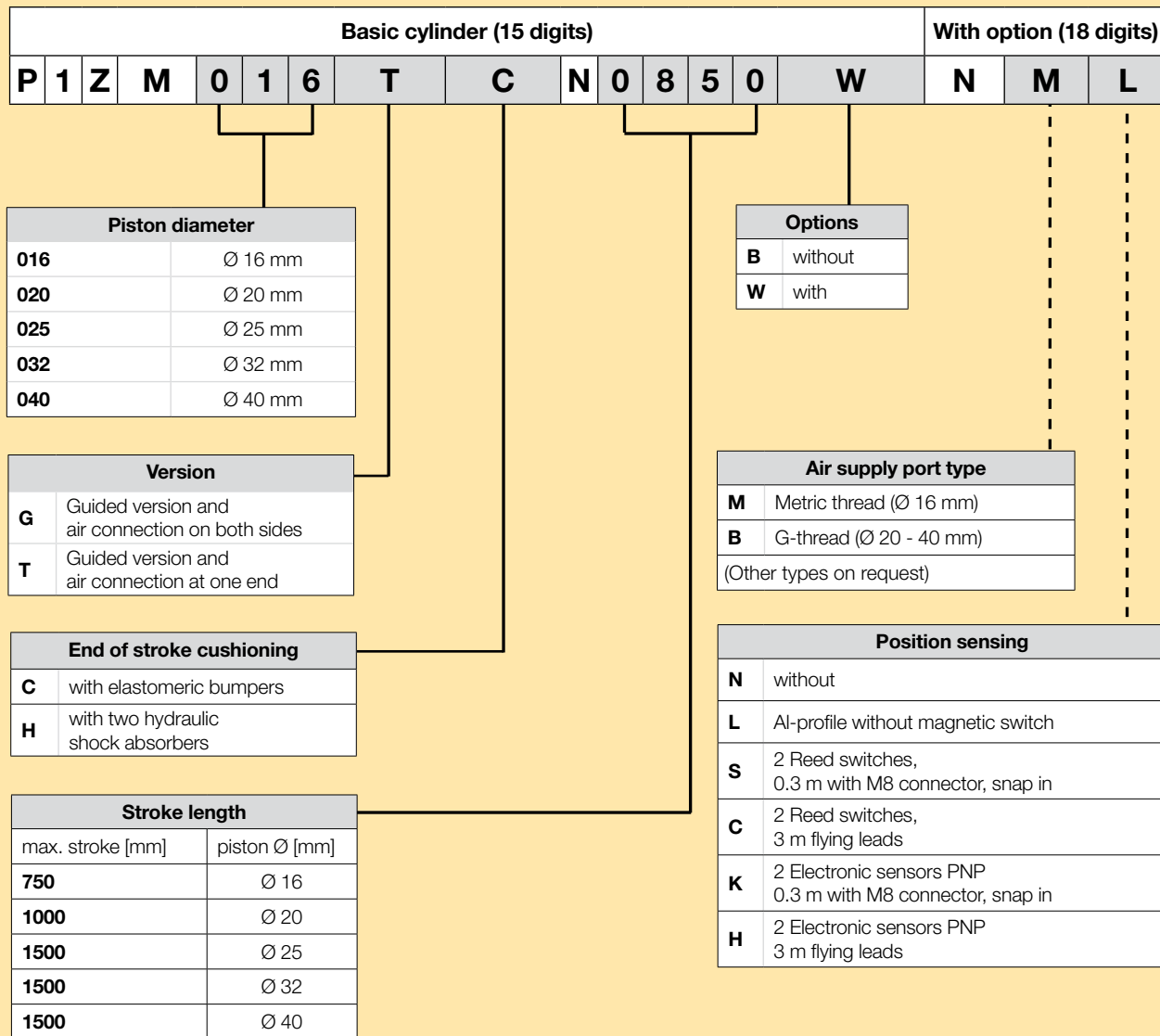

Order code examples:

- **P1ZM016TCN0100B**      Cylinder guided version -Ø 16 mm, stroke 100 mm, with air connection at one end and elastomeric bumpers.
  
- **P1ZM020GHN1000WNBL**      Cylinder guided version -Ø 20 mm, stroke 1000 mm, with air connection on both sides, with two hydraulic shock absorbers and profile rail for magnetic switches.

For further technical information see catalogue P-A4P019GB

Cylinder bore mm	Series	Stroke	Bore mm	Piston rod mm	Area cm <sup>2</sup>	Max theoretical force in N										
						1.0 bar	2.0 bar	3.0 bar	4.0 bar	5.0 bar	6.0 bar	7.0 bar	8.0 bar	9.0 bar	10.0 bar	
10/4	P1A P1S	Double acting	+	10	4	0.8	8	15	23	31	39	46	54	62	69	77
			-	10	4	0.7	6	13	19	26	32	39	45	52	58	65
12/5	C05	Double acting	+	12	5	1.1	11	22	33	44	55	67	78	89	100	111
			-	12	5	0.9	9	18	28	37	46	55	64	73	83	92
12/6	P1A P1Q P1S	Double acting	+	12	6	1.1	11	22	33	44	55	67	78	89	100	111
			-	12	6	0.8	8	17	25	33	42	50	58	67	75	83
16/6	P1A P1S	Double acting	+	16	6	2.0	20	39	59	79	99	118	138	158	178	197
			-	16	6	1.7	17	34	51	68	85	102	119	136	153	170
16/8	P1Q	Double acting	+	16	8	2.0	20	39	59	79	99	118	138	158	178	197
			-	16	8	1.5	15	30	44	59	74	89	104	118	133	148
20/8	P1A P1S	Double acting	+	20	8	3.1	31	62	92	123	154	185	216	247	277	308
			-	20	8	2.6	26	52	78	104	129	155	181	207	233	259
20/10	C05 P1Q P5T	Double acting	+	20	10	3.1	31	62	92	123	154	185	216	247	277	308
			-	20	10	2.4	23	46	69	92	116	139	162	185	208	231
25/10	P1A P1Q P1S P5T	Double acting	+	25	10	4.9	48	96	144	193	241	289	337	385	433	482
			-	25	10	4.1	40	81	121	162	202	243	283	324	364	405
32/12	C05 P1D P1P P1Q P1S P1D-B P1D-C P1D-X	Double acting	+	32	12	8.0	79	158	237	316	394	473	552	631	710	789
			-	32	12	6.9	68	136	203	271	339	407	475	542	610	678
			+	32	12	8.0	80	161	241	322	402	483	563	643	724	804
			-	32	12	6.9	69	138	207	276	346	415	484	553	622	691
			+	32	12	8.0	80	161	241	322	402	483	563	643	724	804
			-	32	12	6.9	69	138	207	276	346	415	484	553	622	691
32/16	P5T	Double acting	+	32	16	8.0	79	158	237	316	394	473	552	631	710	789
			-	32	16	6.0	59	118	178	237	296	355	414	473	533	592
40/16	P1D P1D-C	Double acting	+	40	16	12,6	126	251	377	503	628	754	880	1005	1131	1257
			-	40	16	10,6	106	212	318	424	530	636	742	848	954	1060
40/12	P1P	Double acting	+	40	12	12,6	123	247	370	493	616	740	863	986	1109	1233
			-	40	12	11,4	112	224	337	449	561	673	785	897	1010	1122
40/16	P1Q P1D-B P1D-C P1D-X	Double acting	+	40	16	12,6	123	247	370	493	616	740	863	986	1109	1233
			-	40	16	10,6	104	207	311	414	518	621	725	828	932	1036
			+	40	16	12,6	126	251	377	503	628	754	880	1005	1131	1257
			-	40	16	10,6	106	212	318	424	530	636	742	848	954	1060
50/16	C05 P1P	Double acting	+	50	16	19,6	193	385	578	770	963	1156	1348	1541	1734	1926
			-	50	16	17,6	173	346	519	692	865	1037	1210	1383	1556	1729
50/20	P1D P1Q P1S P5T P1D-B P1D-C P1D-X	Double acting	+	50	20	19,6	193	385	578	770	963	1156	1348	1541	1734	1926
			-	50	20	16,5	162	324	485	647	809	971	1133	1295	1456	1618
			+	50	20	19,6	196	393	589	785	982	1178	1374	1571	1767	1963
			-	50	20	16,5	165	330	495	660	825	990	1155	1319	1484	1649

Cylinder bore mm	Series	Stroke	Bore mm	Piston rod mm	Area cm <sup>2</sup>	Max theoretical force in N										
						1.0 bar	2.0 bar	3.0 bar	4.0 bar	5.0 bar	6.0 bar	7.0 bar	8.0 bar	9.0 bar	10.0 bar	
63/16	C05 P1P	Double acting	+	63	16	31.2	306	612	917	1223	1529	<b>1835</b>	2141	2446	2752	3058
			-	63	16	29.2	286	572	858	1144	1430	<b>1717</b>	2003	2289	2575	2861
63/20	P1D P1Q P1S P5T P1D-B P1D-C P1D-X	Double acting	+	63	20	31.2	306	612	917	1223	1529	<b>1835</b>	2141	2446	2752	3058
			-	63	20	28.0	275	550	825	1100	1375	<b>1650</b>	1925	2200	2475	2750
			+	63	20	31,2	312	623	935	1247	1559	<b>1870</b>	2182	2494	2806	3117
			-	63	20	28,0	280	561	841	1121	1402	<b>1682</b>	1962	2242	2523	2803
			+	63	25	50,3	503	1005	1508	2011	2513	<b>3016</b>	3519	4021	4524	5027
			-	63	25	45,4	454	907	1361	1814	2268	<b>2721</b>	3175	3629	4082	4536
80/25	P1D P1Q P1S P5T P1D-B P1D-C P1D-X	Double acting	+	80	25	50.3	493	986	1479	1972	2466	<b>2959</b>	3452	3945	4438	4931
			-	80	25	45.4	445	890	1335	1780	2225	<b>2670</b>	3115	3560	4005	4450
			+	80	25	50,3	503	1005	1508	2011	2513	<b>3016</b>	3519	4021	4524	5027
			-	80	25	45,4	454	907	1361	1814	2268	<b>2721</b>	3175	3629	4082	4536
84/20	C0D300	Double acting	+	84	20	55.4	544	1087	1631	2175	2718	<b>3262</b>	3806	4349	4893	5436
			-	84	20	52.3	513	1026	1539	2051	2564	<b>3077</b>	3590	4103	4616	5128
100/25	P1D P1Q P1S P5T P1D-B P1D-C P1D-X	Double acting	+	100	25	78.5	770	1541	2311	3082	3852	<b>4623</b>	5393	6164	6934	7705
			-	100	25	73.6	722	1445	2167	2889	3612	<b>4334</b>	5056	5779	6501	7223
			+	100	25	78,5	785	1571	2356	3142	3927	<b>4712</b>	5498	6283	7069	7854
			-	100	25	73,6	736	1473	2209	2945	3682	<b>4418</b>	5154	5890	6627	7363
			+	100	25	101,9	1000	2000	3000	4000	5000	<b>6000</b>	7001	8001	9001	10001
			-	100	25	98,8	969	1939	2908	3877	4846	<b>5816</b>	6785	7754	8724	9693
125/32	P1D P1S P1D-B P1D-C P1D-X	Double acting	+	125	32	122.7	1204	2408	3612	4815	6019	<b>7223</b>	8427	9631	10835	12039
			-	125	32	114.7	1125	2250	3375	4500	5625	<b>6750</b>	7875	9000	10125	11250
			+	125	32	122,7	1227	2454	3682	4909	6136	<b>7363</b>	8590	9817	11045	12272
			-	125	32	114,7	1147	2294	3440	4587	5734	<b>6881</b>	8027	9174	10321	11468
161/25	C0D1200	Double acting	+	161	25	203.9	2000	4000	6000	8000	10000	<b>12000</b>	14000	16000	18000	20000
			-	161	25	199.0	1952	3904	5856	7808	9759	<b>11711</b>	13663	15615	17567	19519
160/40	P1E P1D-T	Double acting	+	160	40	201.1	1972	3945	5917	7890	9862	<b>11835</b>	13807	15779	17752	19724
			+	160	40	201,0	2010	4019	6029	8038	10048	<b>12058</b>	14067	16077	18086	20096
			-	160	40	188,4	1884	3768	5652	7536	9420	<b>11304</b>	13188	15072	16956	18840
200/40	P1E	Double acting	+	200	40	314.2	3082	6164	9246	12328	15410	<b>18491</b>	21573	24655	27737	30819
200/50	P1D-T	Double acting	+	200	50	314,2	3142	6283	9425	12566	15708	<b>18850</b>	21991	25133	28274	31416
			-	200	50	294,5	2945	5891	8836	11781	14727	<b>17672</b>	20617	23562	26508	29453
250/28	C0P2500	Double acting	+	250	28	490.9	4815	9631	14446	19262	24077	<b>28893</b>	33708	38524	43339	48155
			-	250	28	484.7	4755	9510	14265	19020	23776	<b>28531</b>	33286	38041	42796	47551
250/50	P1D-T	Double acting	+	250	50	490,9	4909	9818	14726	19635	24544	<b>29453</b>	34362	39270	44179	49088
			-	250	50	471,3	4713	9425	14138	18850	23563	<b>28275</b>	32988	37700	42413	47125
320/63	P1D-T	Double acting	+	320	63	804,25	8043	16085	24128	32170	40213	<b>48255</b>	56298	64340	72383	80425
			-	320	63	773,1	7731	15462	23192	30923	38654	<b>46385</b>	54116	61846	69577	77308

+ = Outward stroke  
- = Return stroke

**Note!**  
Select a theoretical force 50-100% larger than the force required

The Force Guide is only for double acting cylinders, please look into the technical catalogue for every individual sigle acting cylinder to see the forces.

**Note!** For all single acting cylinders you have to reduce the force in the table with the spring force to get the theoretical force.  
The spring force is not calculated to create any work, it is only to take the piston rod into the cylinder.